



sasportonline.com

Sales & Service

SA Sport (Canada)
135 Forestview Road
P.O. Box 40
Orillia, Ontario
Canada L3V 6H9

Telephone: (705) 325-2274
Fax: (705) 325-1485
Toll Free: (800) 563-6479

SA Sport (U.S.A.)
7879 Will Rogers Blvd.
Fort Worth, Texas
USA 76140

Telephone: (817) 536-3366
Fax: (817) 536-3006
Toll Free: (800) 331-8068

5151 PERFORMANCE SERIES INTERNATIONAL RING FRAME

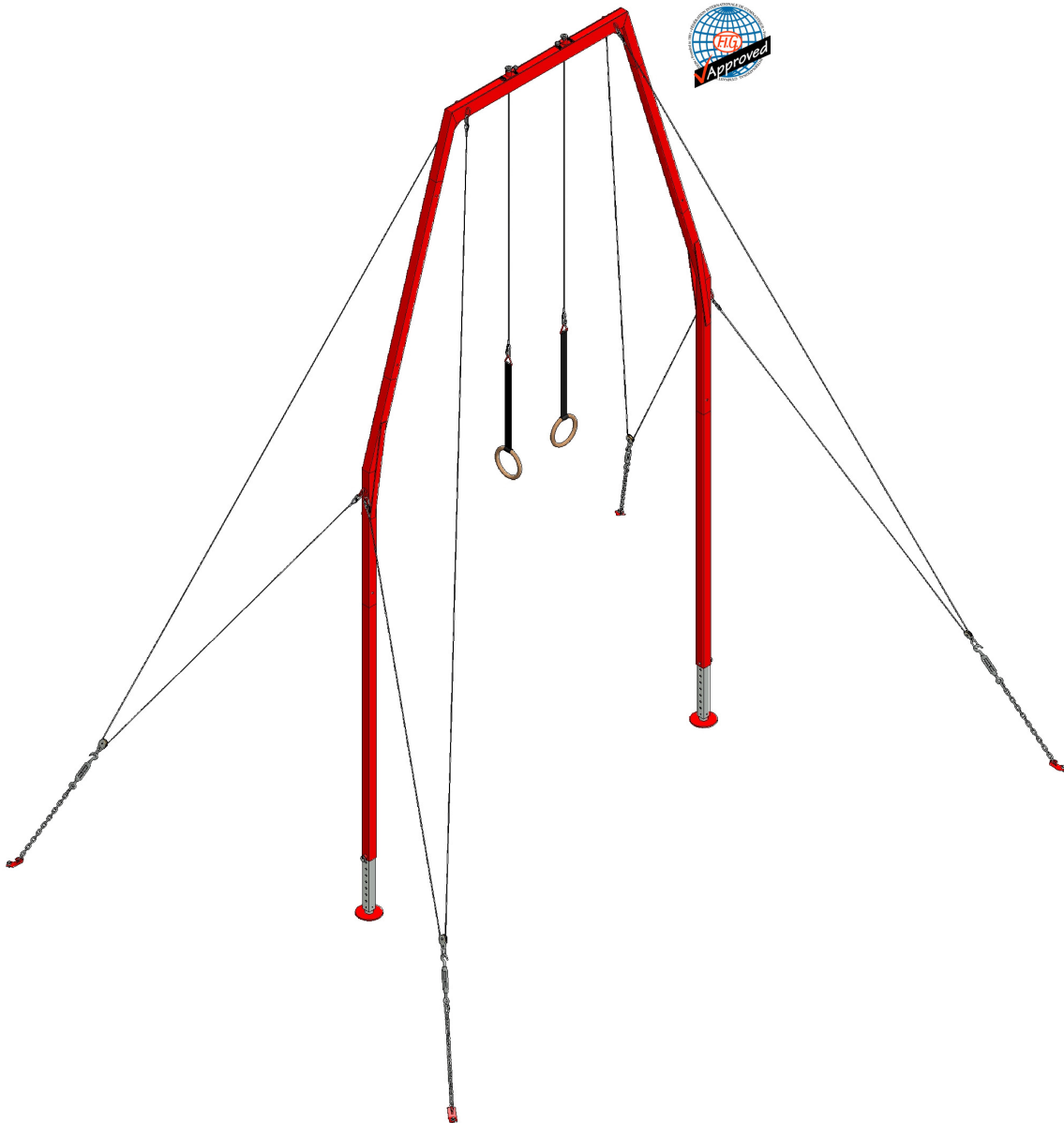

5151 Performance Series International Ring Frame
08/11/2010

SECTION I

Thank you for purchasing a SA Sport "**Performance Series International Ring Frame**". We appreciate your business and value you as a customer.

You have purchased an outstanding designed product. This Ring Frame comes complete with Rings and Cable Tie-Down System. Floor sockets are not included and must be purchased separately if not already installed in your facility.

Please carefully read the following instructions before assembling and using your new piece of equipment.

Warranty: SA Sport Still Ring Frames are guaranteed for one year from date of purchase against faulty manufacturing and defective materials. Damage or breakage, which, in the opinion of the Company, is caused by misuse or mishandling, is not covered by warranty. Proper assembly, dismantling, storage and maintenance will ensure years of trouble free use.



The exclamation mark symbol when seen in this booklet is used to indicate warnings or items that require special attention during the use or assembly of the apparatus.



Only qualified persons should undertake assembly, installation and adjustment of this equipment. At no time should children or other unqualified persons undertake the assembly, installation or adjustment of this equipment.

For assembly, set-up and adjustment instructions, please read and follow all instructions and safety precautions in Section II & III of this booklet as they apply to your particular piece of equipment.

Component Checklist:

You will have received two (2) shipping cartons. The following component parts should be identified before assembly begins. Refer to Figure A to assist with the identification of the components.

Carton 1:

1. One (1) "A" Frame assembly, pre-assembled with Rings, Cables, Straps and Swivels

Carton 2:

1. Two (2) No. 1 Long Upright Tubes, assembled with Adjusting Tubes and hardware
2. Two (2) No. 2 Upright Tubes, Two (2) No. 3 Upright Tubes, Two (2) Base Plates
3. Four (4) Cables (Assembled with Pulley Holders)
4. Eight (8) Quick Links, to be attached to each Cables Looped end.
5. Four (4) Chains, complete with Turnbuckles
6. Four (4) 184 Threaded Socket Adaptors
7. One (1) Hook for catching Rings
8. One (1) Allen Key for attaching Base Plates

Tools required:

1. One (1) extension ladder, one (1) stepladder and a carpenter's level.

SECTION II

Assembly & Installation Instructions:



You will need eight (8) people to assemble the Ring Frame. Do not attempt assembly of this apparatus with less assistance, as it cannot be done safely!

Install Base Plates to Adjusting Tubes (Figure A):

1. Select the two longest (#1) Uprights (those assembled with Adjusting Tubes). Remove the Ball Joint and the Flat Head Socket Cap Screw from the base of the Adjusting Tube.
2. With Uprights lying on the floor, insert the Flat Head Socket Cap Screw through the bottom of the Base Plate, up through the Ball Joint and into the bottom of the Adjusting Tube.



Ensure that the Rubber Foot Pad on the bottom of the Base Plate will be floor side down when the Still Rings Frame is standing upright. Also ensure that the coned top of the Ball Joint is positioned INTO the Adjusting Tube.

3. Tighten the Base Plate securely using the Allen Key provided.
4. Repeat this procedure for the second Adjusting Tube.

Assembly of Upright Tubes (Figure A):

1. Correctly position Upright Tubes on the floor.
2. Slide together #2 Upright Tubes into #1 Uprights until red painted steel butts together on both Uprights.
3. Slide together #3 Upright Tubes into #2 Uprights until red painted steel butts together on both Uprights.
4. Slide the "A" Frame assembly into #3 Upright Tubes until red painted steel butts together on both Uprights.

Cable/Chain Assembly (Figure A):

1. Selecting either the front or the rear and with the Uprights still lying on the floor, attach one end of one Cable using a Quick Link over the Loop on #2 Upright Tube and hook the other end of the Cable/Quick Link over the Loop on the A-Frame assembly. Tighten the Quick Link fully using 2 adjustable wrenches immediately!
2. Attach the remaining three (3) Cables as in step 1. Remember to keep the Cables untwisted.
3. Open the Turnbuckles (fastened to Chains) until only one thread is showing on the internal part of the Turnbuckle.
4. Hook the Turnbuckles into the Pulley Holders on the four Cables. These Chains may be positioned on any Cable.



Keep cables straight and untwisted at all times. Before assembly it is suggested to unravel the Cables and position them to be mounted on either the front or the rear of the Still Ring Frame. See Figure A.

Figure A

- Installation of Base Plates to Adjusting Tubes
- Assembly of Upright Tubes
- Quick Link/Cable/Chain Assembly
- Chain Attachment to Floor Sockets

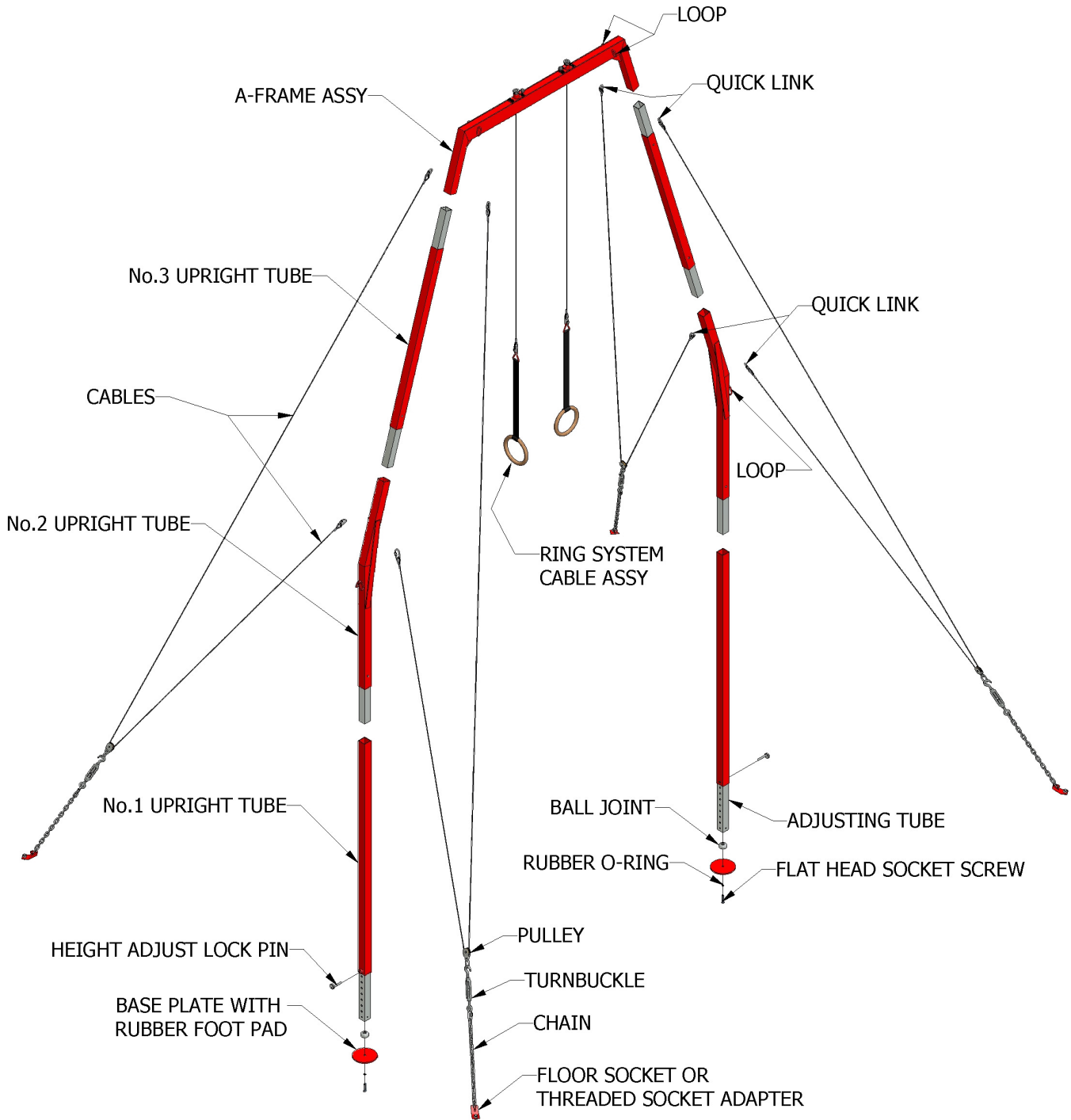

Leg Height Adjustment (Figure B):

1. With the Uprights now completely assembled and the Cables and Chains lying on the floor, set the Adjusting Tubes to the desired height. As of January 1 2010 the official F.I.G. height specification is **280 cm**, measured from the inside bottom of the Ring to the floor. (See Fig. D)



Leaving 7 holes showing below the height Locking Pin will achieve the official FIG height.

2. Insert the Height Adjustment Locking Pin fully into the Locking Collar in the Upright Tube. Turn the Pin until it locks into position. It cannot be removed when locked properly.



It is important that the large end of the Height Adjustment Locking Pin is positioned on the outside of the Frame, facing away from the inside working area between the Uprights.

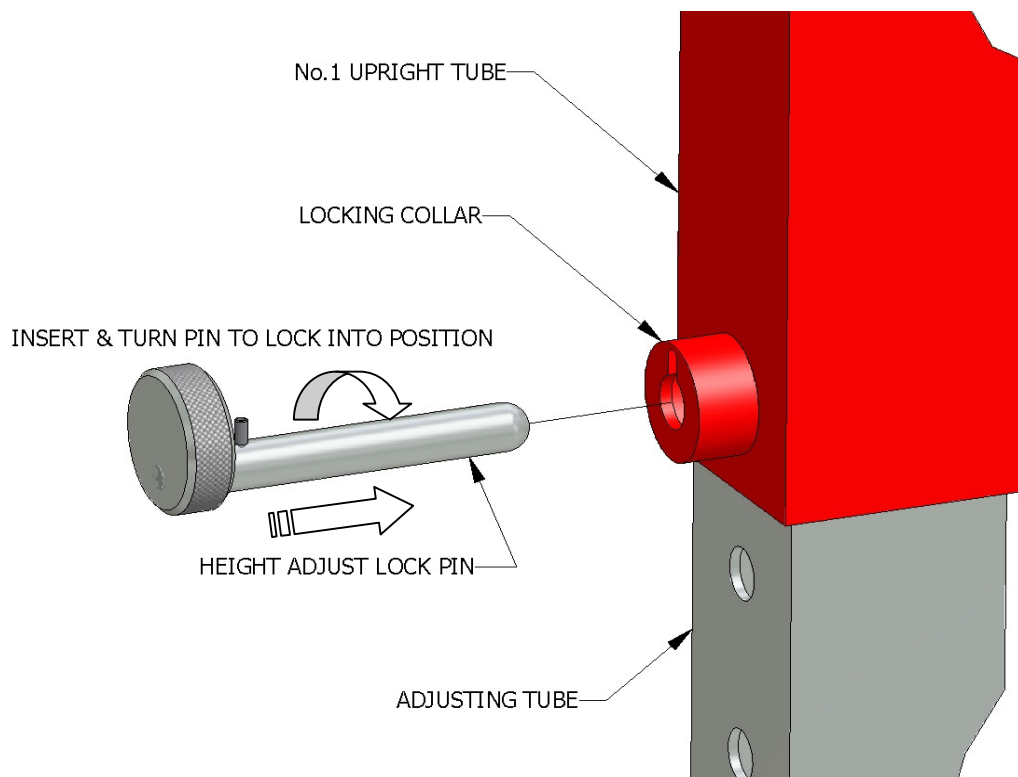

Figure B

Raising the Frame:



You will require eight (8) people to raise the Still Rings Frame into position. Do not attempt this step with less assistance, as it cannot be done safely!

Position 8 people as follows:

- 1 Person** to hold all Cables on the right side.
- 1 Person** to hold all Cables on the left side.
- 1 Person** on the left side of the Frame and support the right side Base Plate.
- 1 Person** on the right side of the Frame and support the left side Base Plate.
- 2 Persons** on the right side of the head "A" Frame.
- 2 Persons** on the left side of the head "A" Frame.



Carefully "walk" the Frame into a vertical position. Ensure that the persons on the sides support the Base Plates so they will not slide out from under!

Ensure that the persons supporting the head "A" Frame do so securely so that it will not work loose from the Uprights. The persons holding the Chains and Cables will assist in raising the Frame by pulling forward.

Chain Attachment to Floor Sockets (Fig. A):



Ensuring that the Frame is properly and securely supported by three people on each side, proceed to attach the Chains to the floor sockets.

Ensure the turnbuckles on all 4 chains are fully extended equally, until only one thread is showing on the internal part of the Turnbuckle.

Cables/Chains Front:

Selecting the tightest possible link, attach the Chains to their respective floor sockets. Start by counting the number of links in both Chains on one side of the Frame. When the links in both these Chains are attached to the floor sockets, the number of links must be equal for both the left and right side. For example, if the left side is hooked into the 20th chain link from the top, the right side must be the same.

Cables/Chain Rear:

As above, Attach the two chains on the opposite side of the Frame to their respective floor sockets. Start by counting the number of links in both Chains and match them to the other side of the Frame. When the links in both these Chains are attached to the floor sockets, the number of links must be equal to all 4 chains. For example, if the left side is hooked into the 20th chain link from the top, the right side must be the same.

Positioning of Still Rings Frame in Floor Socket Layout for Correct Alignment (Fig. C & D):



To ensure proper alignment of your Still Rings Frame, the Base Plates must be equally centered within the floor socket layout.

(See layout measurements-Figure C). The FIG recommended socket layout is 18' 1/2" x 13' 1-1/2" and the alignment instructions are based on this layout. If your floor socket layout does not fit these measurements, you will have to adjust your measurements accordingly.

The distance between the inside of the adjustment tubes measured at the bottom is 9' 8" (see Figure D). Do not attempt to pull the tubes out any wider than this.

Correct tension on the Ring Frame is achieved by using the Turnbuckles:

1. Tighten the Turnbuckles evenly until they are tight and the turnbuckle screws are equally positioned on all 4 cables and the Ring Frame is standing vertical.
2. Now see if the tower leans forward or back. If required equally loosen (back-off) the two Turnbuckles on the side the tower leans towards & then tighten the turnbuckles on the opposite side.
3. You will see that this action makes the Frame lean as tension is changed from side to side.
4. The Frame will straighten upright as this tension is applied correctly.
5. Adjust the turnbuckles as required until the Ring Frame stands vertically and sturdy as explained above.

Figure C

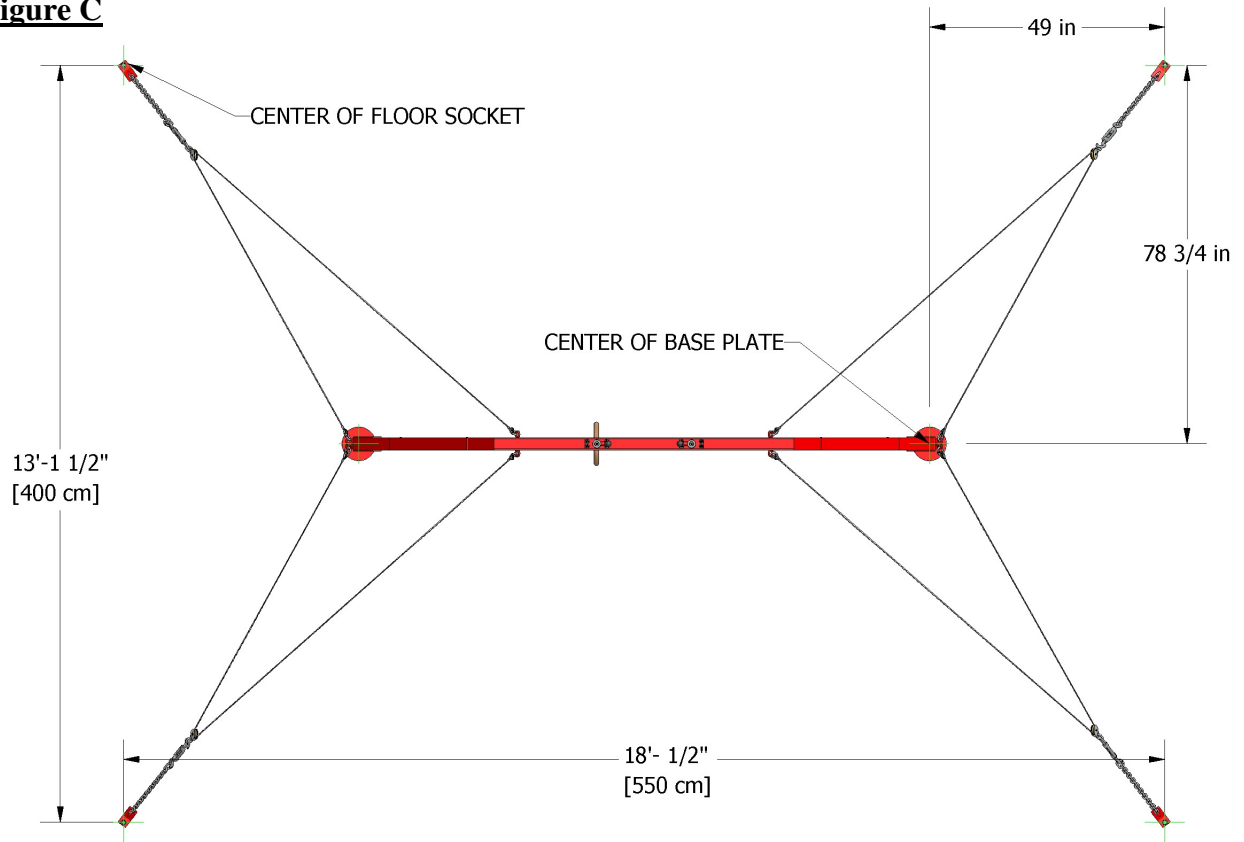
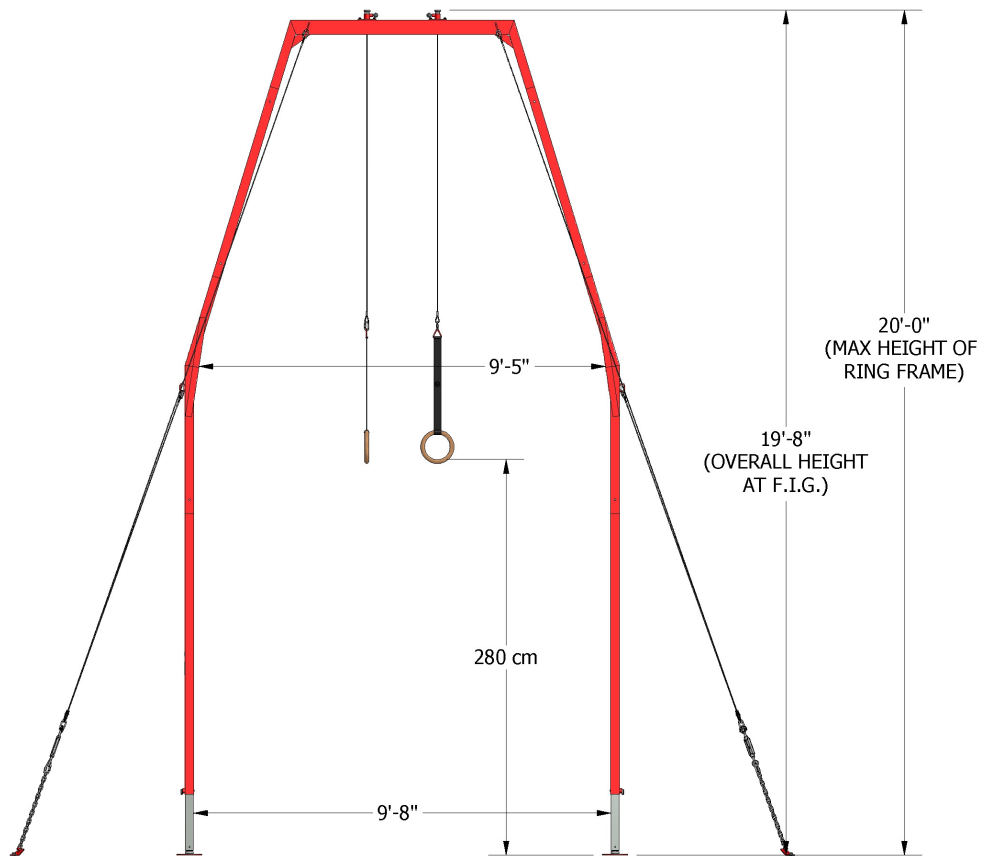

Figure D



Leveling Ring Height (Figure E):

When done properly, this step need only be done once, regardless of the number of height adjustments made to the Rings.

Using an extension ladder, securely stabilized against the frame, climb to the top of the A-Frame assy. At the same time, using a stepladder, have another person climb up and place a carpenter's level between the Rings. To level the Rings, pull the plunger to release it from the Safety Slot. Turn the Adjusting Bolt clockwise to lower ring height. The person viewing the carpenter's level will signal when the Rings are completely leveled.



It is absolutely essential that when leveling is complete, the Plunger be locked back into the Adjusting Bolt. Ensure that this is tested. Try to turn the Adjusting Bolt. If it turns, the Plunger has not been properly inserted back into the Bolt. If it will not turn, the Plunger has been securely locked.

Figure E

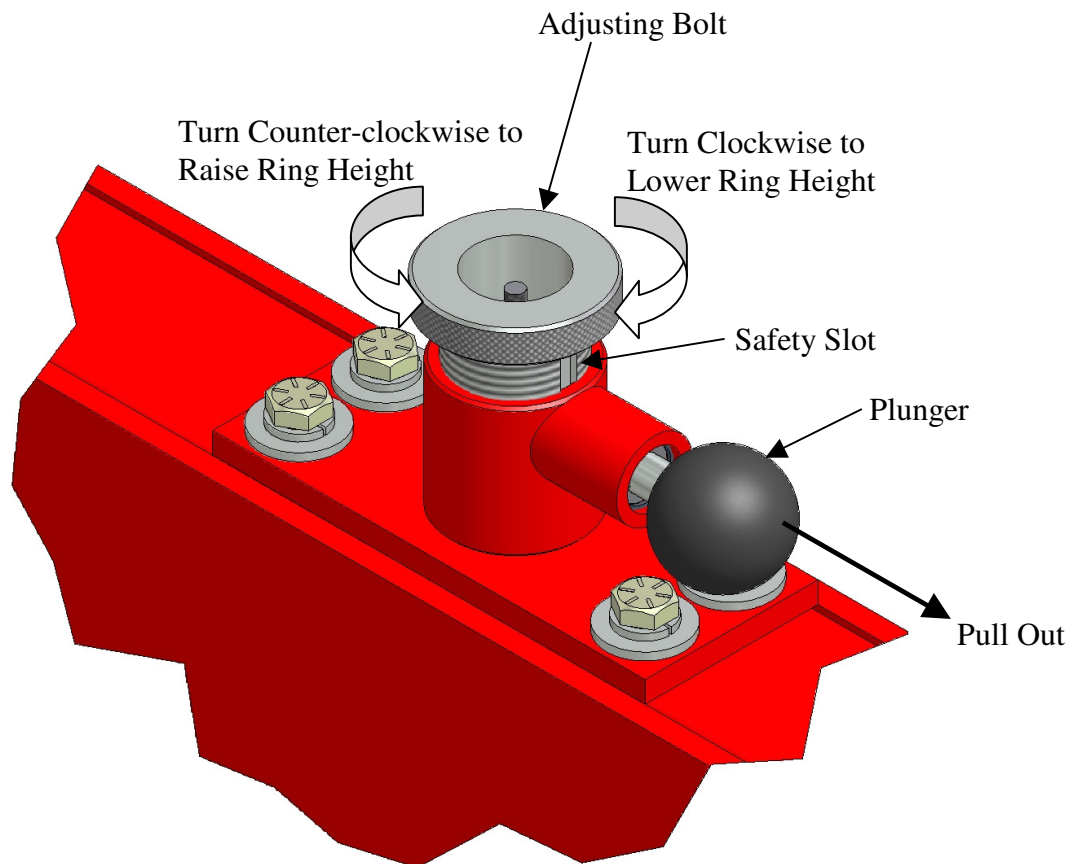

To Disassemble:

Eight people are required to support the Frame during disassembly. Unhook all chains from Floor sockets, ensuring that the Frame and the base Plates are extremely well supported. Carefully "walk down" the Frame to the floor. Do not let it drop down. Disassemble all Upright Tubes for storage.

Enjoy your Performance Series Ring Frame.

SECTION III

Safety and Maintenance:

Safety Check List:

Before initial use:

- Double check that the Cables are securely locked into place at the head of the Frame and that the Plunger is locked back into the Adjusting Bolt.
- Double check that the Base Plates are securely bolted into the Adjusting Tubes, rubber side to the floor.
- Double check that all steel Upright Tubes are securely inserted into each other.

Before each use:

- Visually re-check the overall stability of the Frame.
- Verify that the Height Adjustment Locking Pins are completely pushed through the Upright and Adjusting Tubes and securely locked into position.

During use:

- Ensure that all Turnbuckles have at least 1-2 threads showing

Warning - For your Safety!

Any activity involving motion or height creates the possibility of serious injury including permanent paralysis and even death, from landing or falling on the neck, head or other parts of the body.



You assume a risk of serious injury in using this equipment. However, this risk can be reduced by strictly following these rules at all times.

- Use this equipment **only** under the supervision of a trained and qualified instructor.
- This equipment must be used **only when protected by proper matting as recommended by the International Gymnastics Federation (F.I.G.). If in doubt concerning proper matting, do not use this equipment.**
- This equipment must be used with **proper spotting equipment and qualified spotters** suitable to the activity or skill. Always consult an instructor.
- **Know your own limitations and the limitations of this equipment.** Follow progressive learning techniques and always consult an instructor.
- Always **inspect this equipment for proper stability** before each use.
- Always **inspect this equipment for loose fittings and parts.** Replace any worn, defective or missing parts.
- Always **inspect this equipment for improper or unsafe installation.** If in doubt, do not use this equipment.